

# THE FUJITSU G510-S

Bill Dispenser Unit  
Spray Type

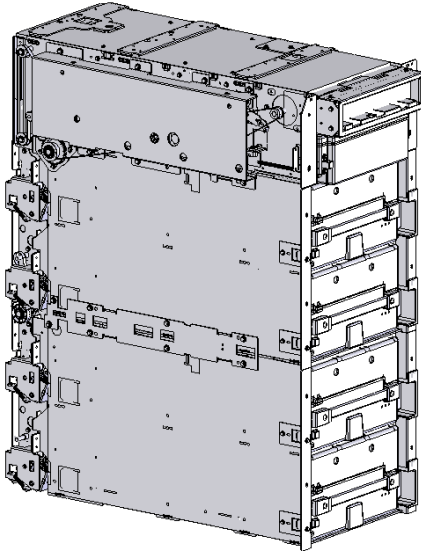

4 Cassettes (Front access) Type

## The Fujitsu G510-S BDU

is one of the most advanced bill dispenser on the market today, with speed, capacity, reliability, and advanced diagnostics for your most demanding environments.

## The Best of Everything.

The Fujitsu G510-S BDU is one of the fastest cash dispensers in the industry. and the G510-S can dispense 100 bills in a transaction.

The unit is expandable to up to four cassettes that can hold up to 3,000 bills each. With a total capacity of 12,000 bills, it is perfect for high-activity installations.

No.	Specifications	G510-S BDU
1	H x W x D : mm	409 x 274 x 550 (2cassettes)
2	Weight (w/o Bills)	32Kg (2cassettes)
3	Number of Cassette	2 (Up to 4 Cassettes)
4	Service Access Side	Front / Rear
5	Bill Count Speed	7 Bill / Sec (USD)
6	Bills Transaction	max 100Bills / Transaction
7	Available Bill Minimum (mm) Maximum (mm)	60 x 120~ ~82 x 166
8	Thickness (mm)	0.07~0.18
9	# of Bills/Cassette	Accommodation 360mm New Notes 3,000 each cassette(Approx.)
10	Safety Standard	Option
11	Reject (Thickness/Length)	Yes
12	Bill Reject Box	Yes
13	Rejectl Box Capacity	200 (Depends on note's conditions)
14	Bill Low Sensor	Yes
15	Interface Specification	RS232C
16	Electrical Power Requirements	DC+24V±10% Max 10A Ave 5A
17	Temperature	Operation 0~40°C Stop State -5~50°C
18	Relative Humidity	Operation 10~85% Stop State 8~95%
19	RoHS-compliant unit	Yes

Rev.01

# THE FUJITSU G510-S

Bill Dispenser Unit  
Spray Type



## Front access

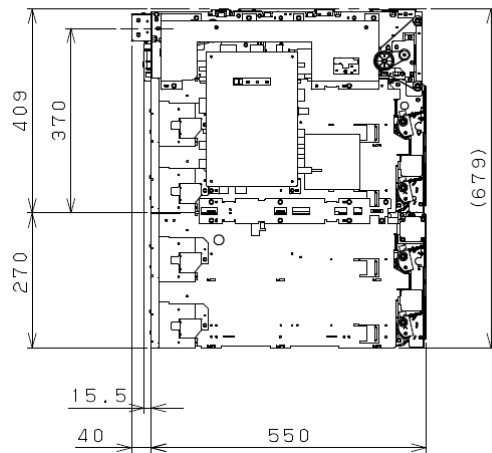
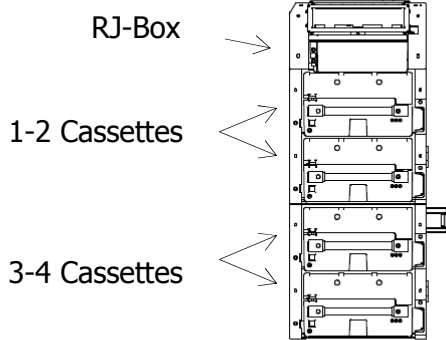
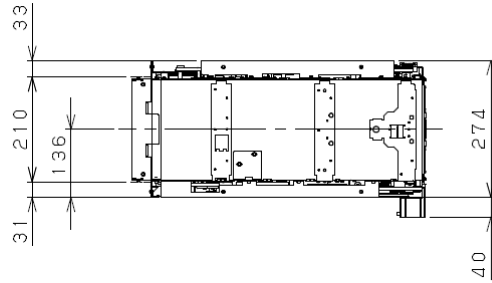

## Rear access

